

## DTF TEXTILE TENSION METER



### PRODUCT DESCRIPTION

#### 1. Introduction

DTF tensiometer for textile is a measuring instrument dedicated to measuring the tension of silk thread in the textile industry, and it can also measure fine metal thread.

#### 2. Features

Adopt the principle of pulley block. The guide wheel is a precision bearing with very little resistance, which makes the measurement result more accurate.

#### 3. Specifications

model	Measuring range (gw)	Minimum scale value (gw)	Accuracy
DTF-25	25-2-25	1	± 1 scale
DTF-50	50-4-50	2	
DTF-75	75-5-75	5	
DTF-100	100-10-100	5	
DTF-150	150-10-150	5	
DTF-250	250-20-250	10	

#### 4. Dimensions

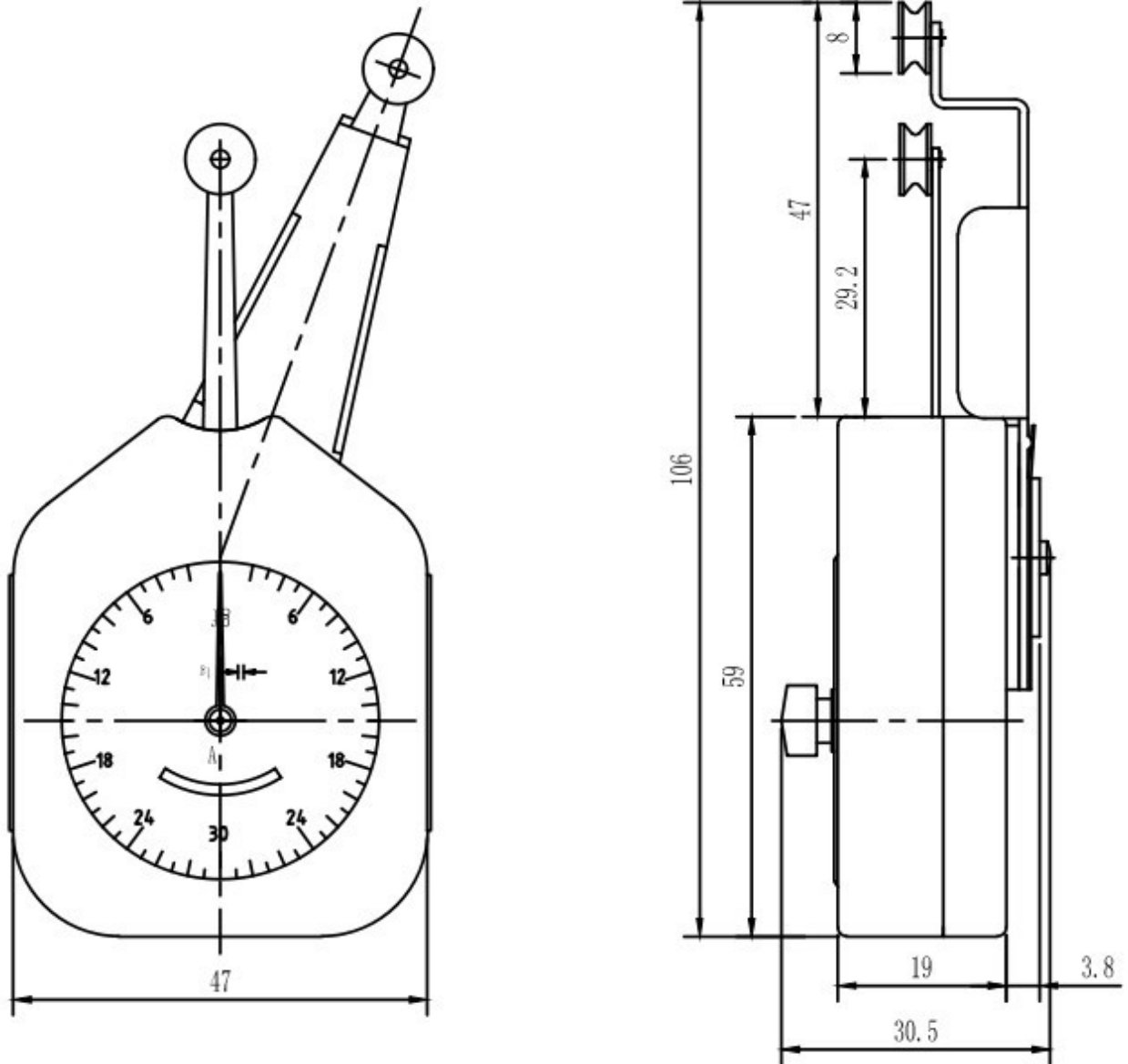

#### 5. Instructions

The specific operation method is shown in the following figure:

## 1、准备

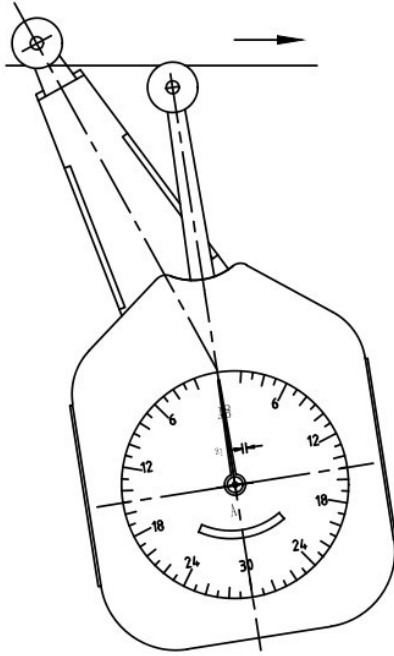

## 2、测定

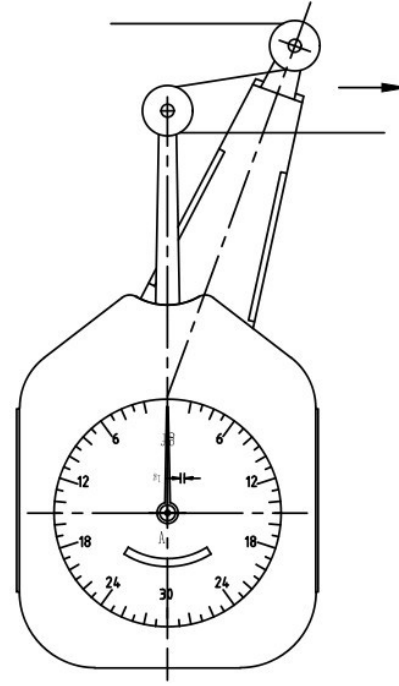

### Other supporting instruments

equipment name	model	equipment name	model
Digital push-pull force gauge	HF	Electric vertical machine	AEV
Pointer push-pull force gauge	NK	Electric single column vertical machine	AEL
Digital torque tester	ANL	Electric horizontal machine	AEH
Bottle Cap Torque Tester	ANL-P	Spiral side roll test machine	ASC
Pointer torque screwdriver	ANQ	Manual horizontal test stand	AMH
High-speed impact torque tester	ACN	Manual vertical and horizontal test stand	ASL
Dynamic torque tester	AND	Hand-pressed tensile and compression test stand	AST
Torque wrench tester	ANJ	Spiral tension and compression test stand	ALX
Torsion spring testing machine	ANH	Special testing machine for peeling force	ABL
Spring tension and compression testing machine	ATH	Ball pressure test device	AQY
Shore Rubber Hardness Tester	LX	Motorized hydraulic tension and compression test stand	ALR
Shore Hardness Test Stand	LAC-J	Button Tester	ABQ
Fruit Hardness Tester	AGY	Terminal tensile tester	ADL
Fruit Hardness Tester Stand	GYJ	Rope tension meter	ASZ
Tonometer	ATN	Side pressure tension tester	HD